

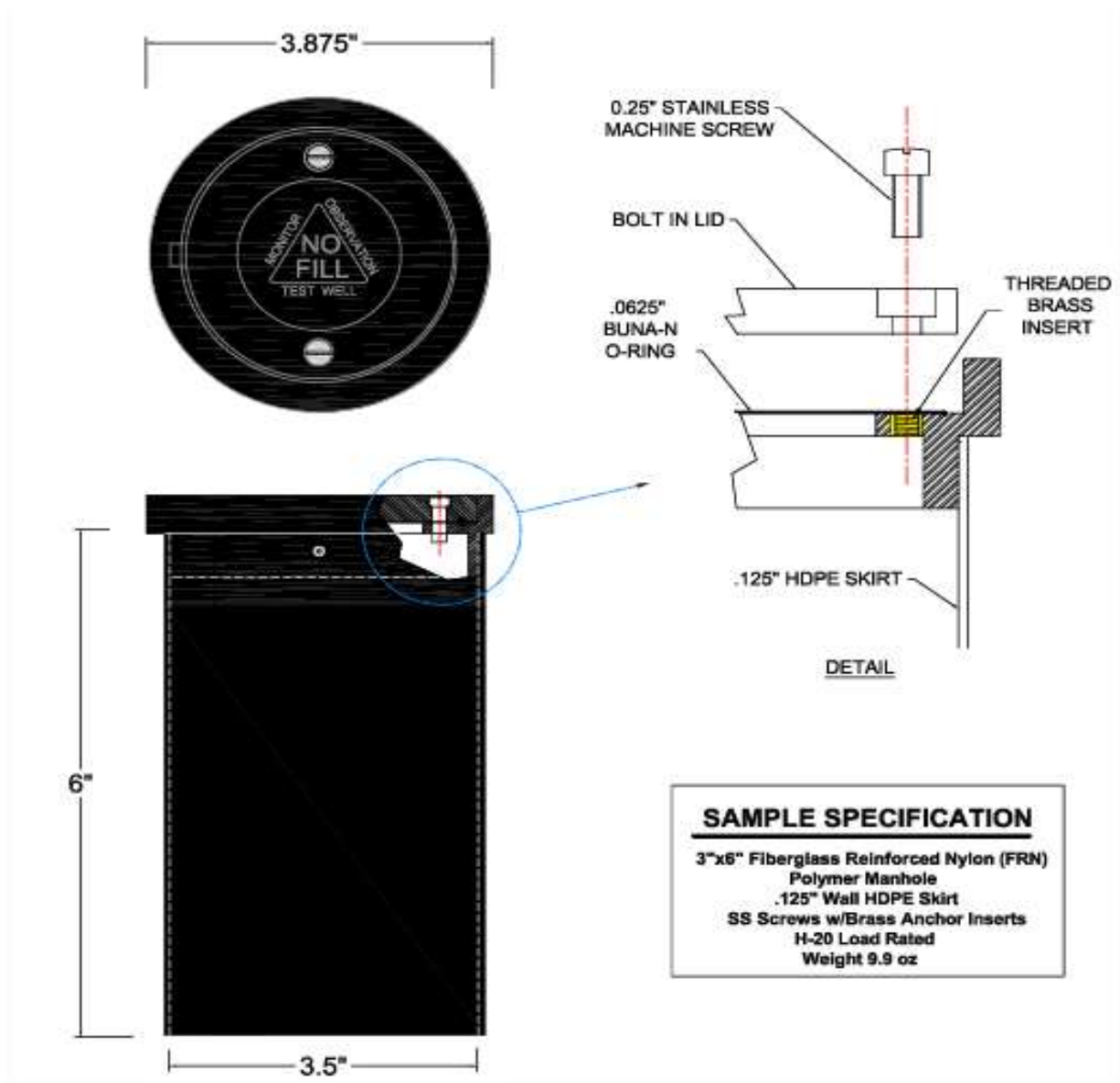

970 MICHELIN
 LAVAL QUEBEC H7L 5C1
 TEL:450-663-9666
 FAX:450-663-9695
 WATT:877-663-9660

BOITES DE SERVICE 3" X 6" NYLON RENFORCÉ DE FIBRE DE VERRE ET JUPE HDPE



SAMPLE SPECIFICATION
 3"x6" Fiberglass Reinforced Nylon (FRN)
 Polymer Manhole
 .125" Wall HDPE Skirt
 SS Screws w/Brass Anchor Inserts
 H-20 Load Rated
 Weight 9.9 oz



BOITES DE SERVICE 4" X 8" NYLON RENFORCÉ DE FIBRE DE VERRE ET JUPE HDPE

970 MICHELIN
 LAVAL QUEBEC H7L 5C1
 TEL:450-663-9666
 FAX:450-663-9695
 WATT:877-663-9660

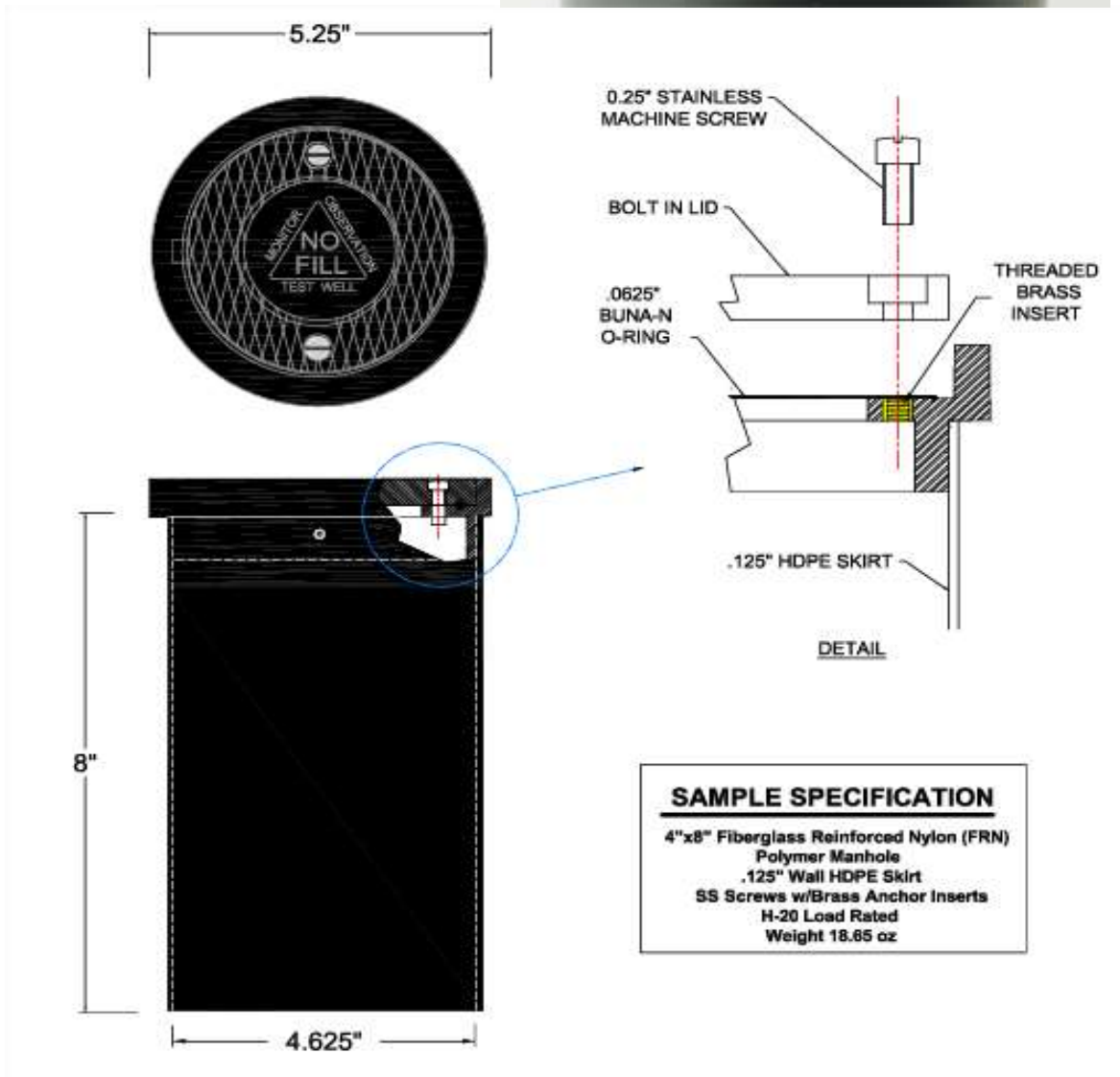

SAMPLE SPECIFICATION

4"x8" Fiberglass Reinforced Nylon (FRN)
 Polymer Manhole
 .125" Wall HDPE Skirt
 SS Screws w/Brass Anchor Inserts
 H-20 Load Rated
 Weight 18.65 oz